

4.20 pH and ORP Sensor Overview

Users can choose between a pH sensor or a combination pH/ORP sensor to measure these parameters. pH describes the acid and base characteristics of water. A pH of 7.0 is neutral; values below 7 are acidic; values above 7 are alkaline. ORP designates the oxidizing-reducing potential of a water sample and is useful for water which contains a high concentration of redox-active species, such as the salts of many metals and strong oxidizing (chlorine) and reducing (sulfite ion) agents. However, ORP is a non-specific measurement—the measured potential is reflective of a combination of the effects of all the dissolved species in the medium. Users should be careful not to overinterpret ORP data unless specific information about the site is known.

(continued)

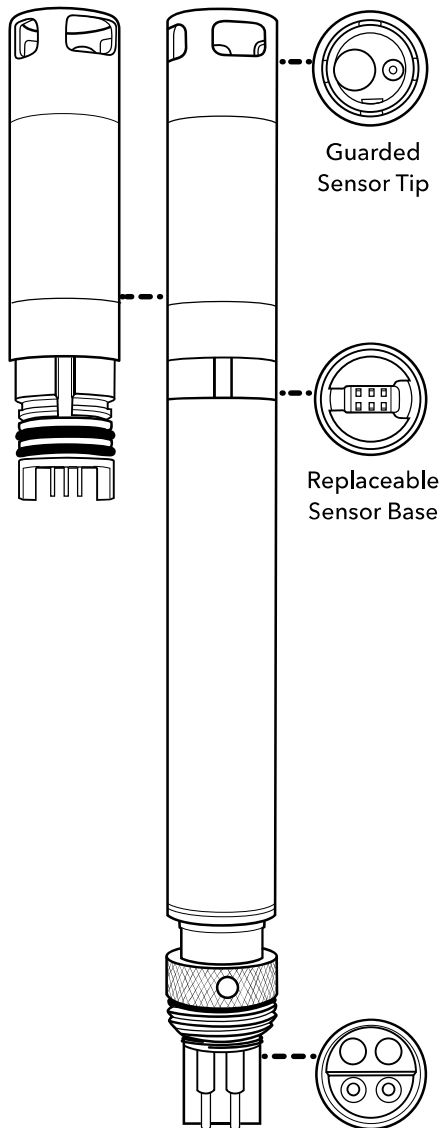

577601, 577602, 577611, 577612;
577603-01, 577603-02, 577613-01,
577613-02 modules

Specifications

pH

Units	pH units
Temperature	
<i>Operating</i>	-5 to +50°C
<i>Storage</i>	0 to 60°C
Range	0 to 14 units
Accuracy	±0.1 pH units within ±10°C of calibration temperature; ±0.2 pH units for entire temp range
Response	T63 < 3 sec
Resolution	0.01 units
Sensor Type	Glass combination electrode

ORP

Units	millivolts
Temperature	
<i>Operating</i>	-5 to +50°C
<i>Storage</i>	0 to 60°C
Range	-999 to +999 mV
Accuracy	±20 mV in Redox standard solution
Response	T63 < 5 sec
Resolution	0.1 mV
Sensor Type	Platinum button

Replaceable Sensor Module

The EXO pH and pH/ORP sensors have a unique design that incorporates a user-replaceable sensor tip (module) and a reusable sensor base that houses the processing electronics, memory, and wet-mate connector. This allows users to reduce the costs associated with pH and pH/ORP sensors by only replacing the relatively inexpensive module periodically and not the more costly base.

The connection of the module to the sensor base is designed for one connection only and the procedure must be conducted in an indoor and dry environment. Once installed the module cannot be removed until you are prepared to replace it with a new module. See [Section 5.14](#) for detailed instructions.

Users must order either a pH or pH/ORP sensor. Once ordered the sensor is *only* compatible with like-model sensor modules. For example, if a pH sensor is purchased initially, then the user must order a replaceable pH sensor module in the future; it cannot be replaced with a pH/ORP module.

Electrodes

EXO measures pH with two electrodes combined in the same probe: one for hydrogen ions and one as a reference. The sensor is a glass bulb filled with a solution of stable pH (usually 7) and the inside of the glass surface experiences constant binding of H^+ ions. The outside of the bulb is exposed to the sample, where the concentration of hydrogen ions varies. The resulting differential creates a potential read by the meter versus the stable potential of the reference.

The ORP of the media is measured by the difference in potential between an electrode which is relatively chemically inert and a reference electrode. The ORP sensor consists of a platinum button found on the tip of the probe. The potential associated with this metal is read versus the Ag/AgCl reference electrode of the combination sensor that utilizes gelled electrolyte. ORP values are presented in millivolts and are not compensated for temperature.

Signal Quality

Signal conditioning electronics within the pH sensor module improve response, increase stability, and reduce proximal interference during calibration. Amplification (buffering) in the sensor head is used to eliminate any issue of humidity in the front-end circuitry and reduce noise.

4.21

pH Calibration

1-point

Select the 1-point option to calibrate the pH probe using one calibration standard.

NOTE: While a 1-point pH calibration is possible, YSI recommends using a 2 or 3-point calibration for greater accuracy.

2-point

Select the 2-point option to calibrate the pH probe using two calibration standards. In this procedure, the pH sensor is calibrated with a pH 7 buffer and a pH 10 or pH 4 buffer depending upon your environmental water. A 2-point calibration can save time (versus a 3-point calibration) if the pH of the media to be monitored is known to be either basic or acidic.

3-point

Select the 3-point option to calibrate the pH probe using three calibration standards. In this procedure, the pH sensor is calibrated with a pH 7 buffer and both the pH 10 and the pH 4. The 3-point calibration method assures maximum accuracy when the pH of the media to be monitored cannot be anticipated.

Review the basic calibration description in [Section 4.2](#).

Pour the correct amount of pH buffer in a clean and dry or pre-rinsed calibration cup. Carefully immerse the probe end of the sonde into the solution, making sure the sensor's glass bulb is in solution by at least 1 cm. Allow at least 1 minute for temperature equilibration before proceeding.

In the Calibrate menu, select pH or pH/ORP, then select Calibrate.

NOTE: Observe the temperature reading. The actual pH value of all buffers varies with temperature. Enter the correct value from the bottle label for your calibration temperature for maximum accuracy. For example, the pH of one manufacturer's pH 7 Buffer is 7.00 at 25°C, but 7.02 at 20°C.

If no temperature sensor is installed, user can manually update temperature by entering a value.

Observe the Pre Calibration Value readings and the Data Stability, and when they are Stable, click Apply to accept this calibration point. Click Add Another Cal Point in the software.

Rinse the sensor in deionized water. Pour the correct amount of the next pH buffer standard into a clean, dry or pre-rinsed calibration cup, and carefully immerse the probe end of the sonde into the solution. Allow at least 1 minute for temperature equilibration before proceeding.

Repeat the calibration procedure and click Apply when the data are stable. Rinse the sensor and pour the next pH buffer, if necessary. Repeat calibration procedure for the third point and click Apply when data are stable.

Click Complete. View the Calibration Summary screen and QC Score. Click Exit to return to the sensor calibration menu.

Rinse the sonde and sensors in tap or purified water and dry.

SmartQC for pH Sensors

The SmartQC Score for pH is based on both a gain and an offset. The offset calculation is based on the millivolts recorded during sensor calibration.

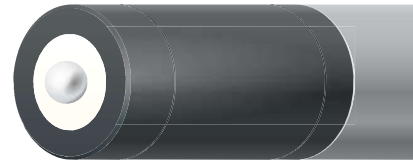

Guidance on interpretation of the SmartQC Score for this sensor is as follows:

 **Green:** Gain and offset are within acceptable limits. Calibration was performed successfully and results are within factory specified limits.

 **Yellow:** Either the gain or the offset is near the threshold of factory specified limits. If a user calibration results in a yellow QC Score, perform the following actions:

1. Ensure that all debris is removed from the surfaces of the sensor. Refer to [Section 5.12](#) for information on proper sensor cleaning in order to avoid damaging the sensor.
2. Verify that there are no cracks or visual damage to the glass bulb.
3. A yellow score can result from a contaminated standard; ensure that all buffers are clear (not cloudy) and free of debris, and that the calibration cup was clean.
4. A Factory Reset Calibration should be performed.
5. The electrolyte solution inside the sensor may be partially depleted which causes the millivolt values to drift over the range of calibration. This is not a user-addressable problem, but to prevent it make sure that sensor modules are stored in the same bottle of solution that was shipped with the new modules. Avoid storage of sensor modules in distilled or deionized water.
6. If the sensor is new, make sure that there are no air bubbles in the pH bulb. Sensors actually do have air in the reference solution, but if the sensor is in the upright position, as it should be during calibration, an air bubble should not be in the bulb. If air bubbles are found, shake the sensor gently to encourage electrolyte solution to flow into the bulb and the air to rise to the top (where it will not be visible).
7. Check the delta slope and mV per decade. Generally, the delta slope should be ≥ 165 mV, and the mV per decade should not deviate by more than 5 units from an ideal of 59.16 (assumes the calibration was performed at or near 25°C). See "Additional Information" below.

If the QC Score returns to yellow, the sensor (or module) is still able to be used but one should be cautious if a long-term deployment is planned. With a yellow QC Score it is more acceptable to use the sensor for discrete sampling because the mV value can be easily monitored under those conditions. In either case, the user should monitor this sensor during calibrations and perform periodic calibration checks for any further drift. Finally, the sensor could be reconditioned by soaking it in a bleach solution and then an HCl solution ([Section 5.12](#)). Persistent yellow QC Scores are a sign that the time to replace the sensor module may be approaching.

 **Red:** The gain or offset is outside of factory specified limits. If a user calibration results in a red QC Score, follow the same steps described above for a yellow QC Score. If the score remains red then replace the sensor module with a new module, perform a Factory Reset Calibration, and calibrate the new module with fresh buffers.

If the QC Score remains red after the Factory Reset Calibration and recalibration, or after replacement of the module and performing a calibration, please contact YSI Technical Support for further assistance. Further, if upon replacement with a new module the QC Score is yellow, contact YSI Technical Support.

Additional QC Information for pH

The calibration worksheet provides information that can be useful for assessing performance of the pH modules with age. Two useful parameters shown there are the “delta slope” and the “mV per decade.” In general the practice is to not use a pH module where the delta slope is less than 165 mV, and the mV per decade deviates by more than 5 units from an ideal of 59.16. However, these ranges assume a calibration was performed at or near to 25°C. For users who wish to better understand the underlying principles for these guidelines, and perhaps to establish their own acceptance criteria, read on.

The Nernst equation is a well-established relationship that governs pH:

$$E = E_o + 2.3RT/\eta F * \text{pH}$$

Where

E = millivolts output

E_o = a constant associated with the reference electrode

T = temperature of measurement in Kelvin

R = the universal gas constant

ηF = the Faraday constant

In simplified $y = mx + b$ form, the relationship is (mV output) = (slope) x (pH) + (intercept). Using this form note that the term $2.3RT/\eta F$ is the slope, and it is sometimes called the Nernst potential.

The absolute value of the Nernst potential, at 298 K (25°C), is 59.16 mV/pH unit. At standard temperature, then, when one would change the pH from 7 to 8, the mV change is expected to be -59.16. Extrapolating further, from pH 7 to pH 10, the mV change would be

$$3 * -59.16 = -177.3 \text{ mV/pH unit.}$$

Similarly, from pH 7 to pH 4 the change would be +177.3 mV/pH unit.

Returning to the Nernst equation, note that these slopes are temperature-dependent. During calibration the mV values for two standard buffer solutions are experimentally established and used by the sonde's software to calculate the slope and intercept of the plot of mV vs. pH. Once this calibration has been performed, the mV output of the probe in any sample can be converted by the sonde into a pH value, *as long as the calibration and the reading are carried out at the same temperature.*

In reality the temperature is almost never the same in environmental monitoring as it is during calibration. Thus a mechanism must be in place to compensate for temperature, effectively converting the slope and intercept of the plot of pH vs. mV established at the temperature of calibration into a slope and intercept at the temperature of measurement.

This mechanism is already provided by the Nernst equation. The slope of the plot of pH vs. mV is *directly proportional* to the absolute temperature in degrees Kelvin. Thus, if the slope of the plot is experimentally determined to be 59 mV/pH unit at 298 K (25°C), then the slope of the plot at 313 K (40°C) must be $(313/298) * 59$, or 62 mV/pH unit. At 283 K (10°C), the slope is calculated to be $(283/298) * 59$, which is 56 mV/pH unit. Determination of the slope of pH vs. mV plots at temperatures different from the calibration temperature is thus straightforward.

How can one apply this information for QC?

First, use the temperature compensation to determine what the slope should be for the calibration that was just performed. A calibration performed at 23°C, for instance, should have a slope of $(296/298) \times 59.16$, or 58.76. The calibration worksheet shows "mV per decade" between calibration points, such as from 4 to 7 and 7 to 10.

It is not unusual for the mV per decade to deviate from the ideal predicted by the Nernst equation, but typically it should not deviate more than 4 to 5 mV per decade. In this example, if the mV per decade is 56.51, that would be acceptable to most users. If it were instead 53.43, that could be cause for concern.

Another valuable piece of information on the calibration worksheet is in the "Delta slope," which is the change in mV per decade across the range being measured. As stated above, in an ideal scenario at standard temperature, the "delta slope" going from pH 7 to pH 4 would be +177.3, and going from pH 7 to pH 10 it would be -177.3. If, as in our example here, the calibration was performed at 23°C, and therefore the a slope of 58.75 were calculated, then the delta slope from pH 7 to pH 4 would be $3 \times 58.75 = 176.25$, and the delta slope from pH 7 to pH 10 would be -176.25.

In general it is advisable that the delta slope should not deviate more than about 12-15 from the ideal. So a delta slope for pH 7 to pH 4 of 161 would be considered unacceptable to most users in the present example.

In practice, people don't usually do these calculations, but rather apply a rule of thumb that states, for a laboratory-based calibration where temperature is often near 25°C, the delta slope should always be ≥ 165 .

With a better understanding of the Nernst equation, however, users can monitor the changes in the mV per decade and delta slope, and look for big changes from prior calibration worksheets. These changes, even when the SmartQC Score is green, can be useful indicators of changes in the performance of the pH module with age.

5.11 pH and pH/ORP Sensors

Storage and Rehydration

pH and pH/ORP sensors have two specific storage requirements: they should not be stored in distilled or deionized water and their reference electrode junction should never dry out. This section will identify storage as “long-term” or “short-term.” Long-term denotes storage during times of long inactivity (over-wintering, end of monitoring season, etc.). Short-term denotes storage during times the sonde will be used at a regular interval (daily, weekly, biweekly, etc.).

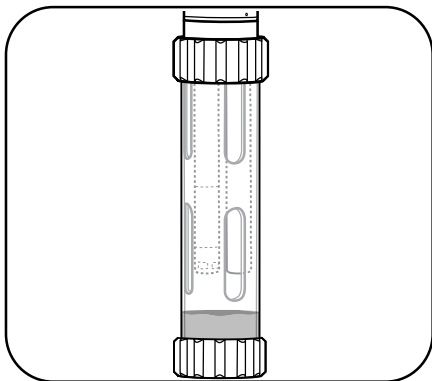

1 Short-term storage

When in regular field use, the sensor should remain installed on the sonde in an environment of water-saturated air. Place approximately 0.5 in (1 cm) of any water (deionized, distilled, tap, or environmental) in the bottom of the calibration cup. Insert the sonde and sensor into the cup and screw it on tightly to prevent evaporation. (More information in “Short-Term Sonde Storage” [Section 5.1.](#))

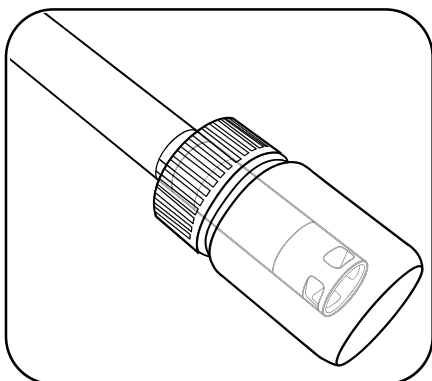

2 Long-term storage

Remove the sensor from the sonde and insert its sensing end into the bottle that the sensor was shipped in. Install the bottle's o-ring and cap then tighten. This bottle contains a 2 molar solution of pH 4 buffer. If this solution is unavailable, users may store the sensor in tap water.

NOTICE: Do not store the pH or pH/ORP sensor in Zobell solution, DI or distilled water.

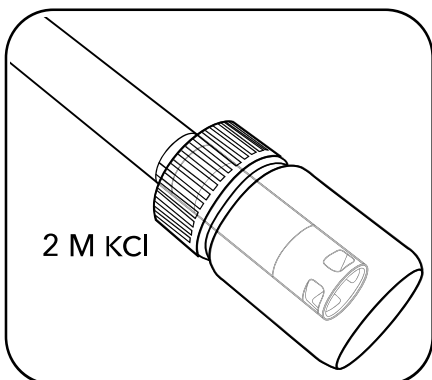

3 Rehydrate reference junction

If the pH sensor has been allowed to dry, soak the sensor for several hours (preferably overnight) in a 2 molar (2 M) solution of potassium chloride (KCl). In order to create a 2 M KCl solution, dissolve 74.6 g of KCl in 500 mL of distilled or deionized water. If KCl is unavailable, a tap water or pH 4 buffer soak may restore function. If the sensor is irreparably damaged, users must replace the sensor module.

5.12 pH and pH/ORP Sensors Maintenance

pH and pH/ORP sensors will require occasional maintenance to clear contamination from the sensing elements. These contaminants can slow the sensor's response time. Clean the sensors whenever deposits, biofouling, or other contamination appear on the glass, or when the sensor's response time slows perceptibly. Remove the sensor from the sonde before performing the following cleaning steps. Do not attempt to physically scrub or swab the glass bulbs. The bulbs are very fragile and will break if pressed with sufficient force.

NOTE: It is important to make sure the sensor connector is lubricated prior to installation. Maintain connectors as instructed in [Section 5.17](#).

Replace depleted sensor module as instructed in [Section 5.14](#).

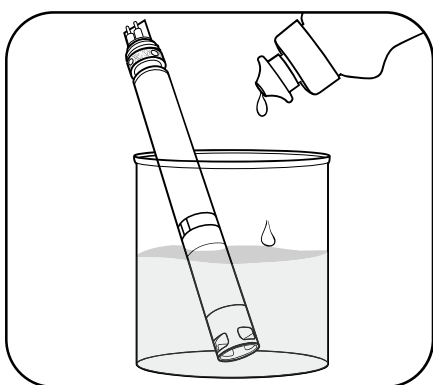

1 Soak in dishwashing liquid solution

Soak the sensor for 10-15 minutes in a solution of clean tap water and a few drops of dishwashing liquid. Following the soak, rinse the sensor with clean water and inspect. If contaminants remain or response time does not improve, continue to the HCl soak.

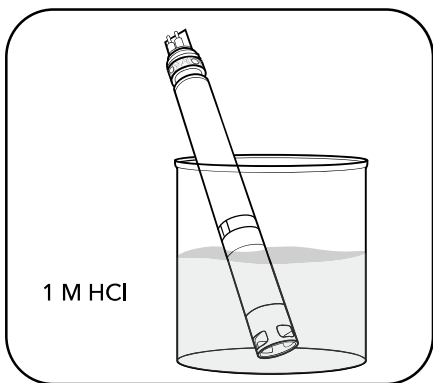

2 Soak in HCl solution

Soak the sensor for 30-60 minutes in one molar (1 M) hydrochloric acid (HCl). This reagent can be purchased from most distributors. Following the HCl soak, rinse the sensor in clean tap water and allow it to soak for an hour in clean water. Stir the water occasionally. Then, rinse the sensor again in tap water and test response time. If response time does not improve or you suspect biological contamination of the reference junction, continue to the next soak. If HCl is not available, soak in white vinegar.



WARNING: Follow the HCl manufacturer's instructions carefully to avoid personal harm.

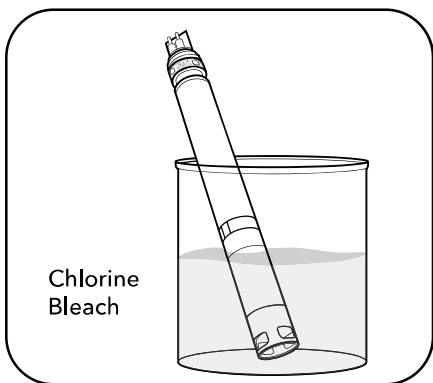

3 Soak in chlorine bleach solution

Soak the sensor for approximately one hour in a 1:1 dilution of chlorine bleach and tap water. Following the soak, rinse the sensor in clean tap water and allow it to soak for at least one hour in clean water (longer if possible). Then, rinse the sensor again in tap water and test response time.

5.14 Sensor Module Replacement

EXO pH, pH/ORP, ammonium, nitrate, and chloride sensors feature replaceable sensor modules (#599795, 599797, 599743-01, 599744-01, 599745-01) due to the electrolyte-depleting characteristics necessary to make such measurements. We recommend that users replace these modules as necessary—typically 12 to 18 months for pH and ORP and three to six months for ISEs, when stored properly. Working life will depend on the conditions of the deployment environment. Perform this procedure in a clean, dry laboratory environment.

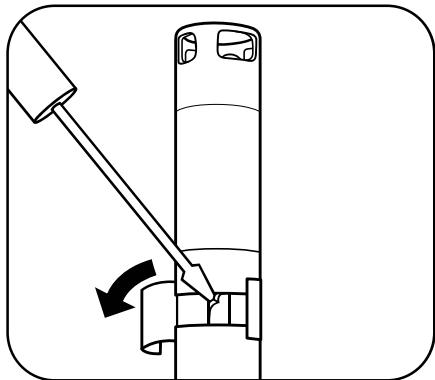

1 Remove old sticker and plug

Peel off and discard the old sticker that covers the junction of the sensor body and the module. Then, with a small, flat-blade screwdriver, remove the small rubber plug from the gap in the hard plastic ring at the base of the sensor module.

CAUTION: Always exercise extra care when using sharp or potentially harmful instruments.

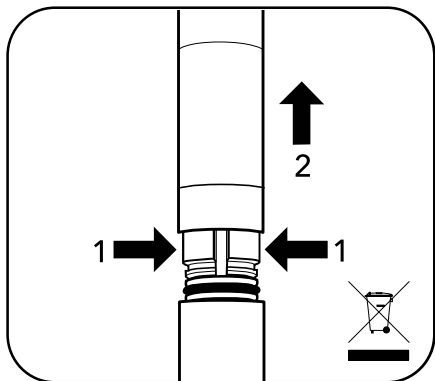

2 Remove and discard old sensor module

To remove, perform two motions simultaneously.

1. With your fingers, squeeze the sensor module's hard plastic ring so that it compresses the gap left by the rubber plug.
2. Steadily pull the sensor module straight back from the sensor body, rocking slightly if necessary.

NOTICE: The act of removing the old sensor module renders the o-rings on the module unusable. To prevent catastrophic leaks, do not attempt to reinstall a module with damaged o-rings. Discard the module and the old o-rings according to your organization's guidelines, or return it to manufacturer for recycling.

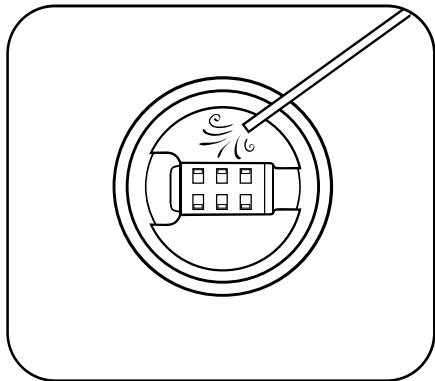

3 Inspect and service connector cavity

Inspect the connector cavity of the probe body for debris or moisture.

If detected, remove it with a lint-free cloth or a gentle blast of compressed air.

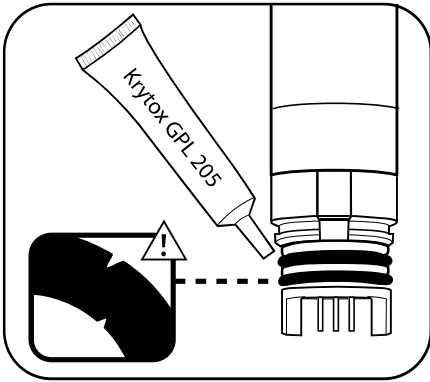

4 Inspect and service new sensor module's o-rings

Ensure that the two o-rings are not nicked or torn and have no contaminants or particles on them. If the user detects damage, carefully replace them with the extras included in the sensor module kit. Then apply a thin coat of Krytox® lubricant to each o-ring. If a user removes a sensor module that is in good working order, replace the o-rings before use.

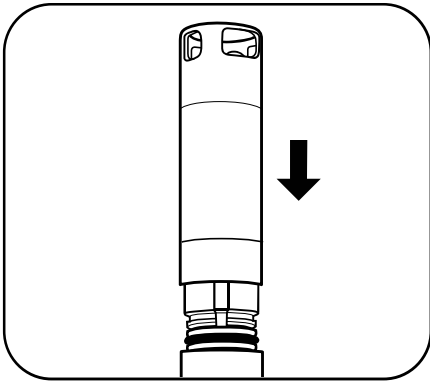

5 Insert new sensor module

Align the prongs on the base of the module with the slots in the sensor body. The sensor module is keyed to insert in only one orientation. Once the module is aligned, press it firmly into position until it clicks. Wipe away any excess grease from the assembled components.

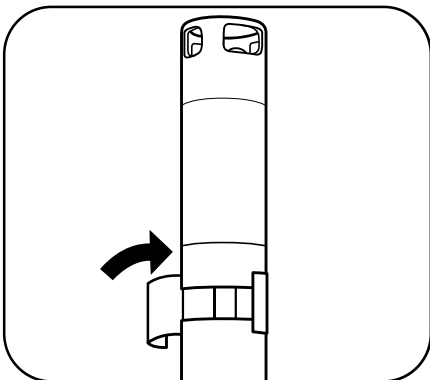

6 Apply new sticker

Wrap the junction of the sensor module and the body with the new sticker included in the sensor module kit. This sticker helps keep the sensor module junction clean and retains the rubber plug throughout deployment.

On the sticker, use a permanent marker to write the date the replacement module was installed, as a reminder.

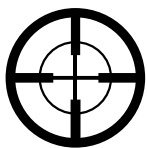

7 Re-calibrate the sensor

Using KorEXO software, calibrate the sensor following each sensor module replacement. After calibration, the sensor is ready for field use.